

US-WA-320-2

Desert Unit Ponds

Frenchman Enhancement

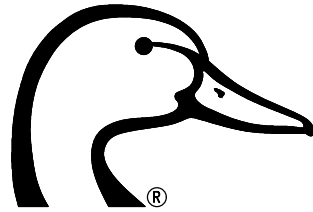

**DUCKS
UNLIMITED**

17700 S. E. MILL PLAIN BLVD. SUITE 100
VANCOUVER, WA. 98683
PH. (360) 885-2011



REFERENCE:

APPLICANT: WDFW

PROPOSED PROJECT:
US-WA-320-2

LOCATION: TAX PARCEL 161217000
LAT/LONG: N 46.974748, W 119.451843

PAGE: 1 OF 15

DATE: 1 NOV 16

IN:

NEAR/AT: (Moses Lake, WA)

COUNTY: Grant

STATE: Washington

ADJACENT PROPERTY OWNERS:

US Bureau of Rec.
WA Department of Natural Res.

COVER SHEET

SHEET INDEX

- 1 Cover Sheet
- 2 Sheet Index, Vicinity Map
- 3 Site Map
- 4 Project Area
- 5 Islands 1 & 2, Plan and Sections
- 6 Island 3, Plan and Section
- 7 Island 4 & 5, Plan and Sections
- 8 Contouring Areas, Plan and Sections
- 9 Access Levee, Plan and Sections
- 10 Swale, Plan and Profile
- 11 New Inlet Ditch & Swale 1
- 12 Swale 2 with optional Dikes & Water Control Structures
- 13 Dikes 1 & 2, Plan View & Detail
- 14 Dike 1 & 2 Sections
- 15 Quantity Summary

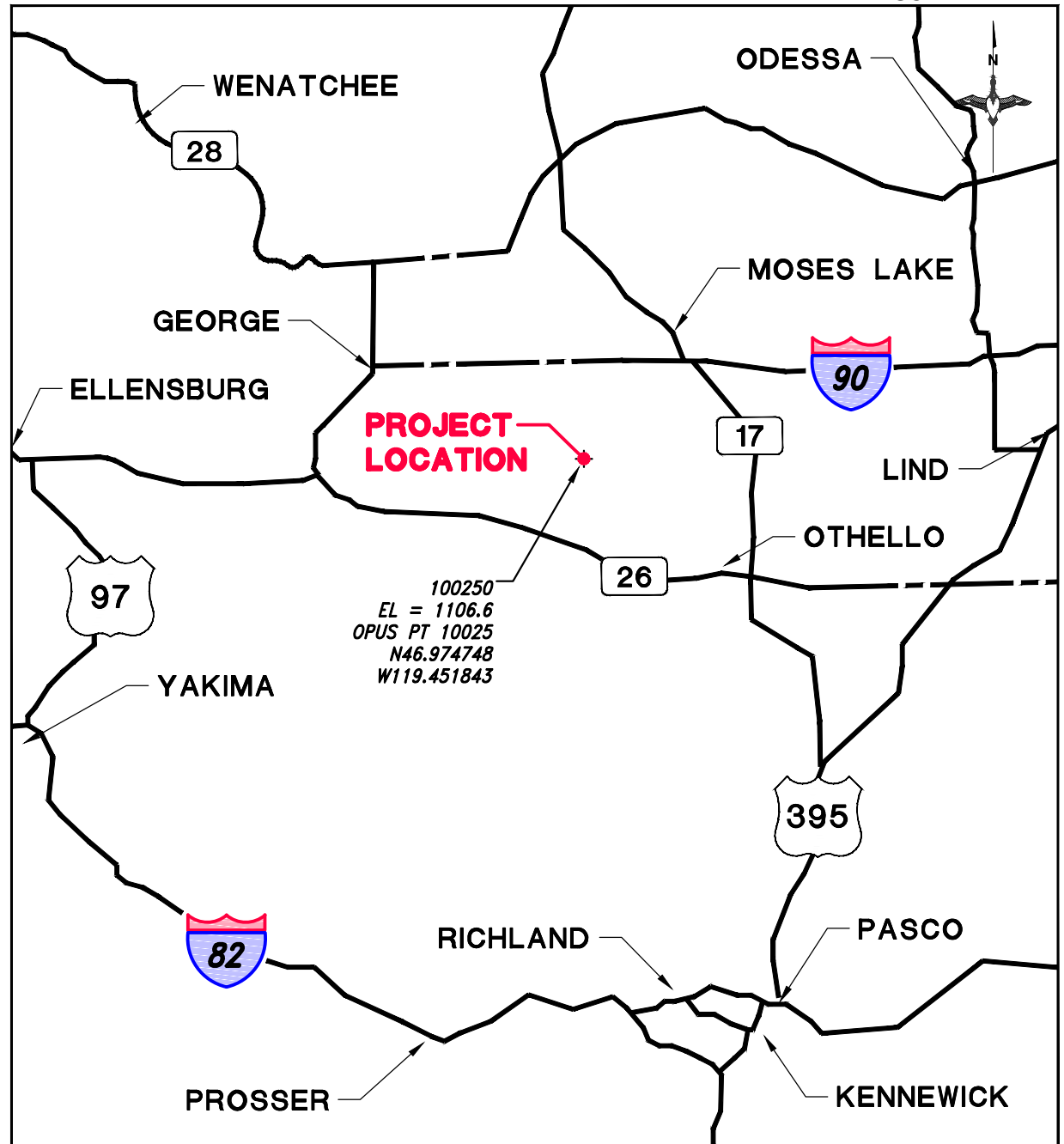
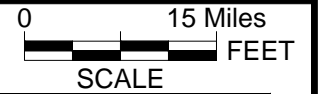

REFERENCE:

APPLICANT: WDFW

PROPOSED PROJECT: US-WA-320-2

LOCATION: Tax Parcel, 161217000

LAT/LONG: N 46.974748, W 119.451843

PAGE: 2 of 15

DATE: 1 NOV 16

**SHEET INDEX &
PROJECT VICINITY MAP**

VICINITY MAP

WASHINGTON

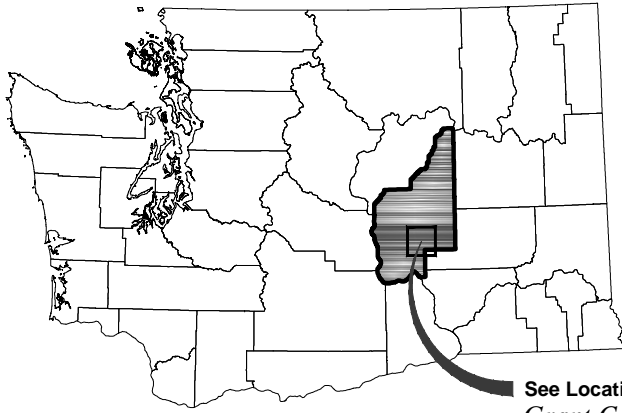

See Location Map
Grant County

SEC 8
T 17 N
R 27 E

SURVEY DATUM

Horizontal: NAD 83
US State Plane Washington South Zone
Vertical: NAVD88
Units: US Feet

Horizontal: Washington State Plane South Zone,
NAD_83(2011)(EPOCH:2010.0000)
Vertical: NAVD 88 (Computed using GEOID12B)
Units: Survey Feet
Horizontal/Vertical Control by 7 Hour GPS Static Observation
Submitted to NGS OPUS

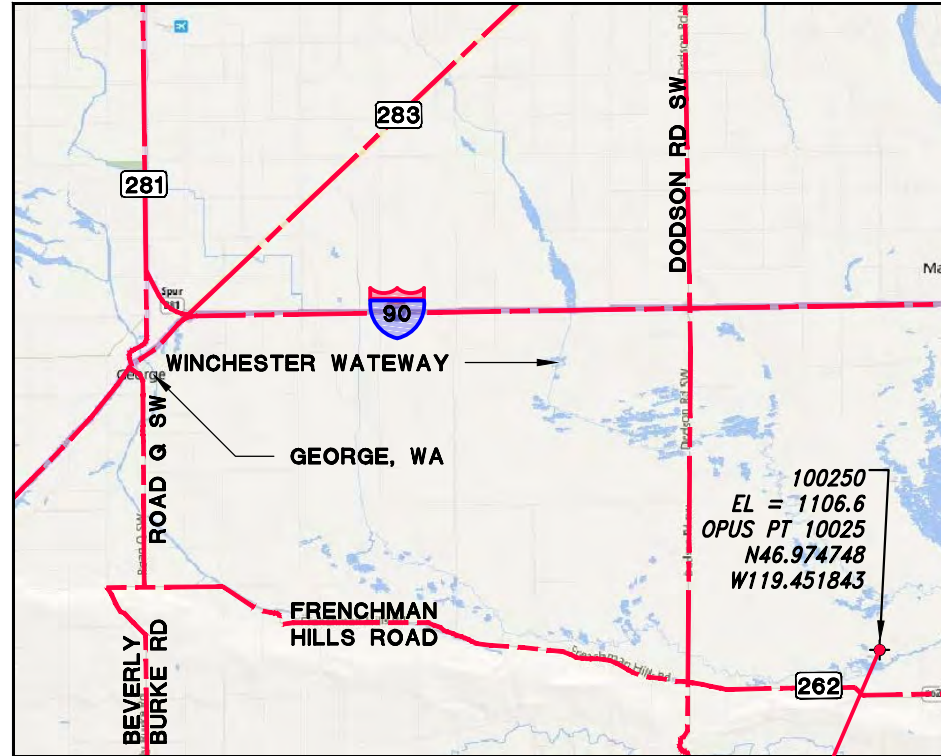
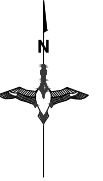

**PROJECT
LOCATION**

REFERENCE:

APPLICANT: WDFW

PROPOSED PROJECT: US-WA-320-2

LOCATION: Tax Parcel 161217000

LAT/LONG: N 46.974748, W 119.451843

PAGE: 3 of 15

DATE: 1 NOV 16

SITE MAP

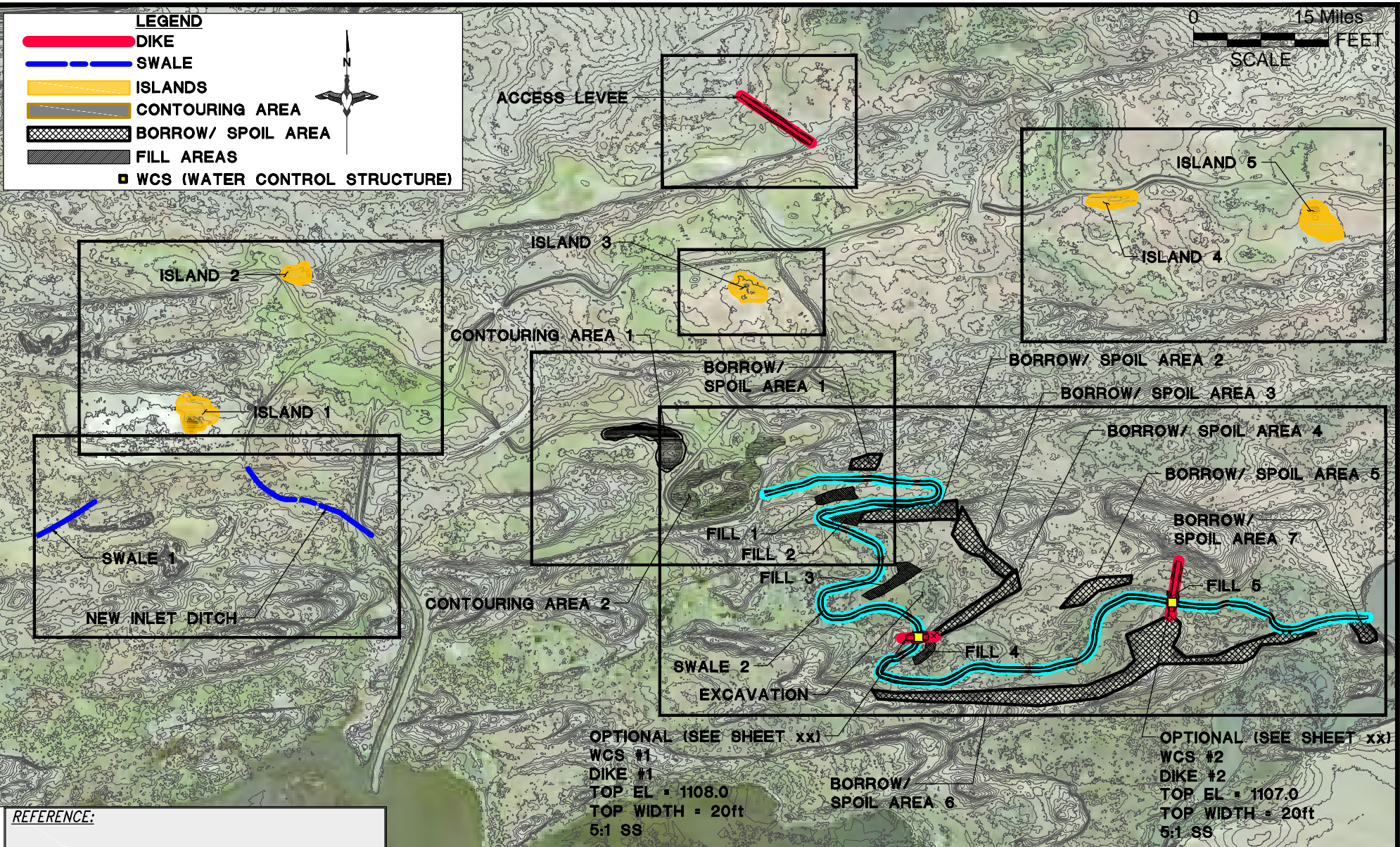

REFERENCE:

APPLICANT: WDFW

PROPOSED PROJECT: US-WA-320-2

LOCATION: Tax Parcel 161217000

LAT/LONG: N 46.974748, W 119.451843

PAGE: 4 of 15 DATE: 1 NOV 16

*Desert Unit Ponds Frenchman
Enhancement Secondary Inlet Swale*

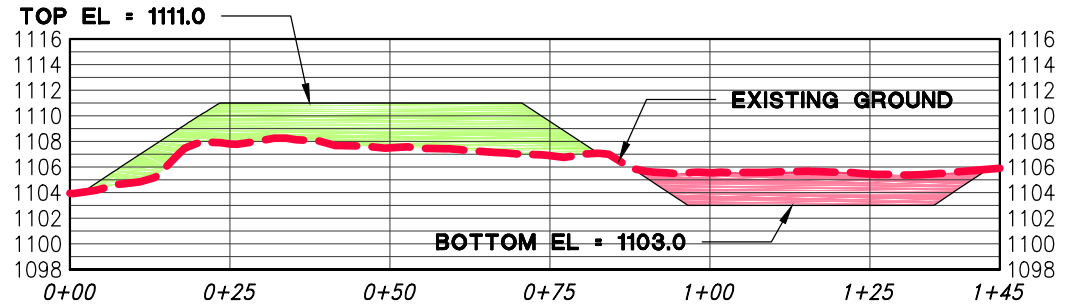
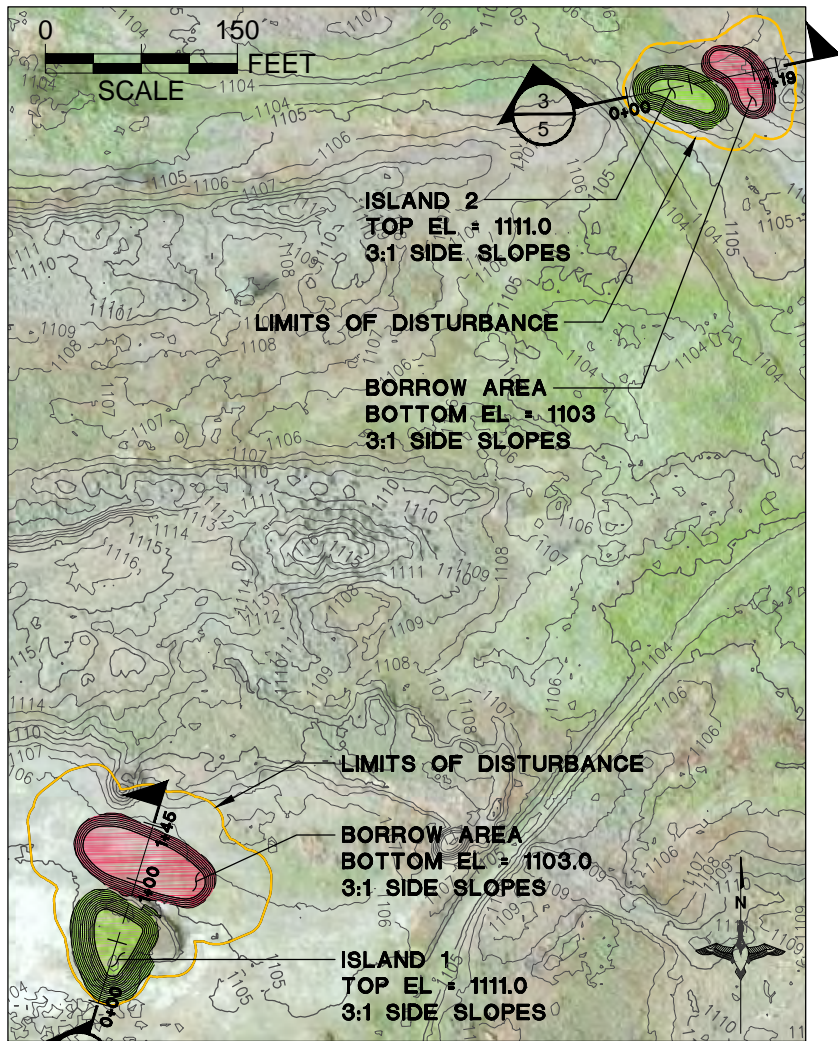

2
5 ISLAND 1 SECTION

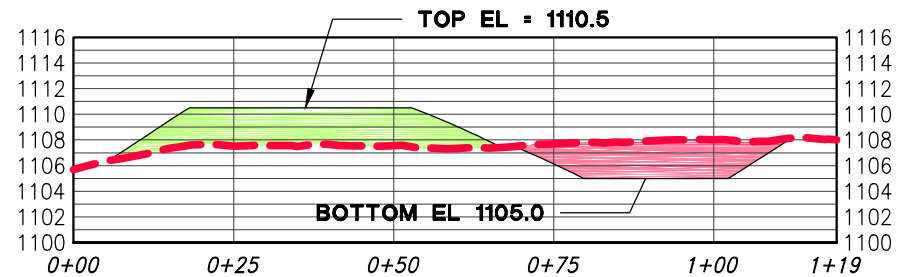

3
5 ISLAND 1 SECTION

1
5 ISLAND 1 & 2 PROFILE

REFERENCE:

APPLICANT: WDFW

PROPOSED PROJECT: US-WA-320-2

LOCATION: TAX PARCEL 161217000

LAT/LONG: N 46.974748, W 119.451843

PAGE: 5 of 15

DATE: 1 NOV 16

Islands 1 & 2

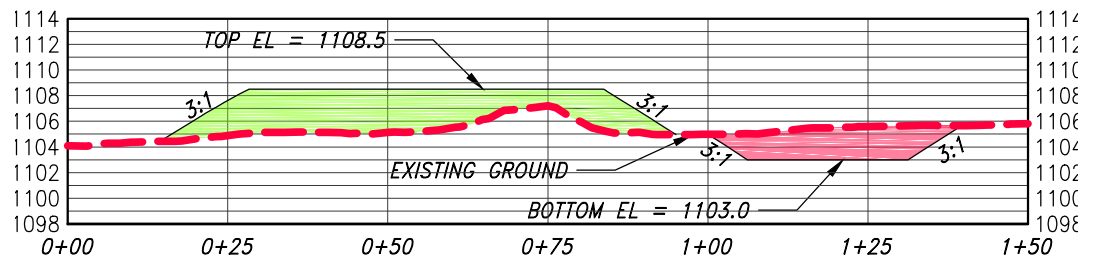
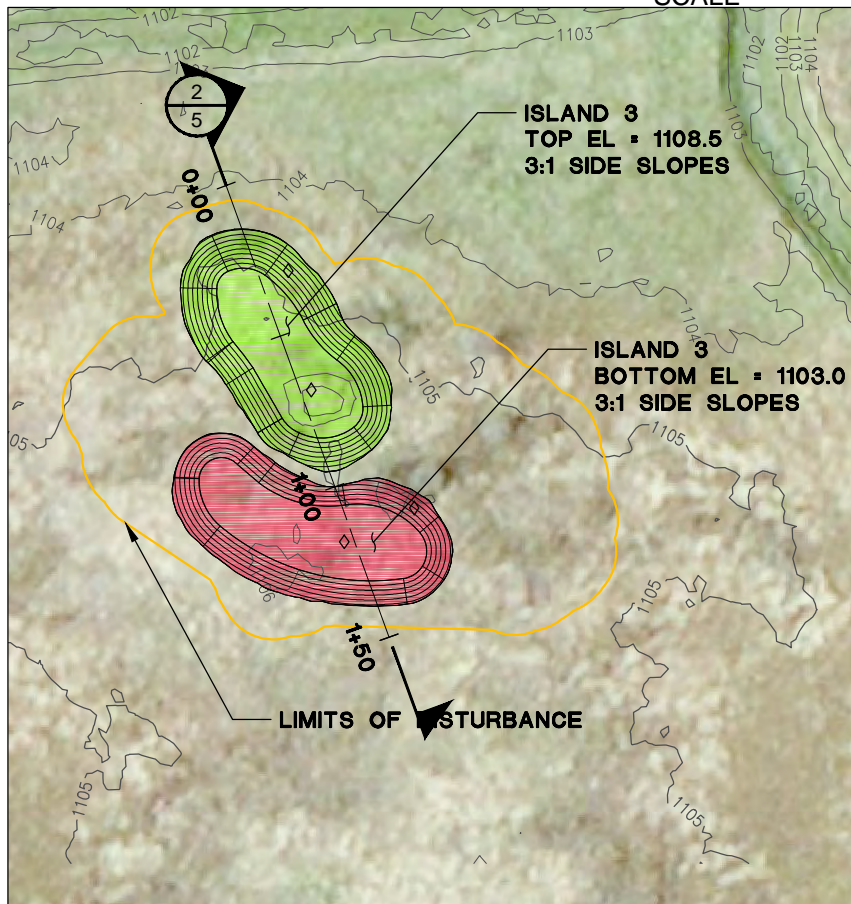
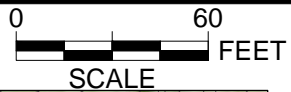

2 ISLAND 3
6 SECTION

1 ISLAND 3
6 PLAN VIEW

REFERENCE:

APPLICANT: WDFW

PROPOSED PROJECT: US-WA-320-2

LOCATION: TAX PARCEL 161217000

LAT/LONG: N 46.974748, W 119.451843

PAGE: 6 of 15

DATE: 1 NOV 16

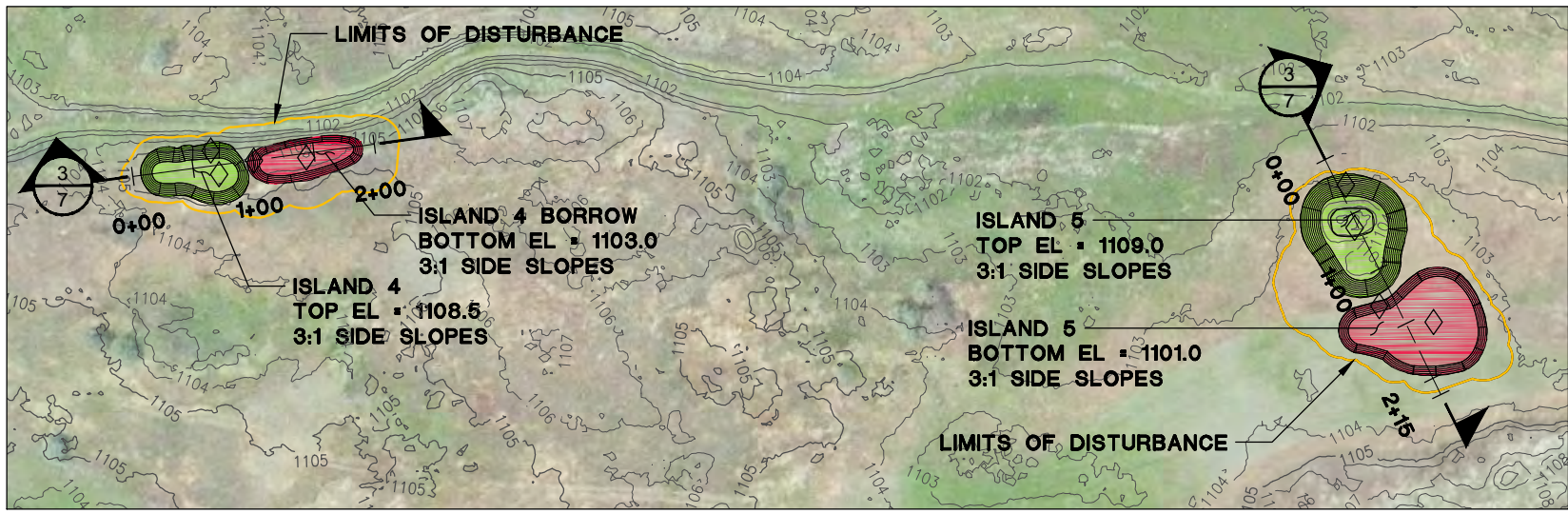
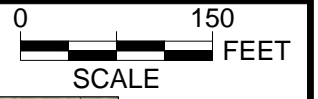

1 ISLANDS 4 & 5
7 PLAN VIEW

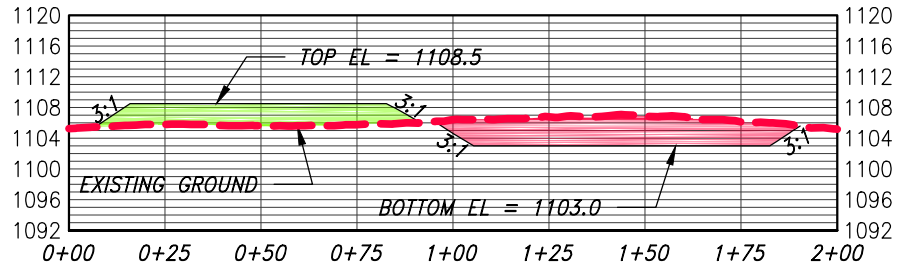

2 ISLAND 4
7 SECTION

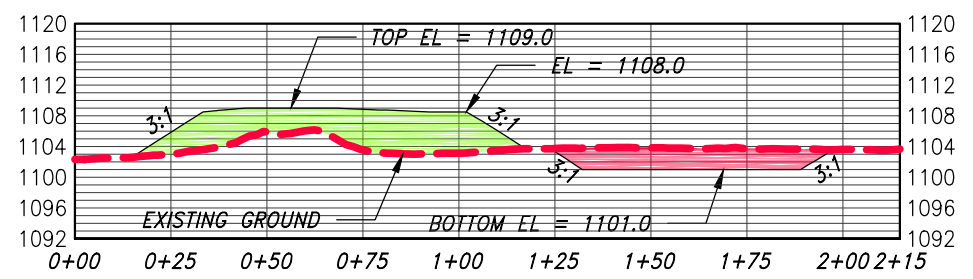

3 ISLAND 5
7 SECTION

REFERENCE:

APPLICANT: WDFW

PROPOSED PROJECT: US-WA-320-2

LOCATION: Tax Parcel 161217000

LAT/LONG: N 46.974748, W 119.451843

PAGE: 7 of 15 **DATE:** 1 NOV 16

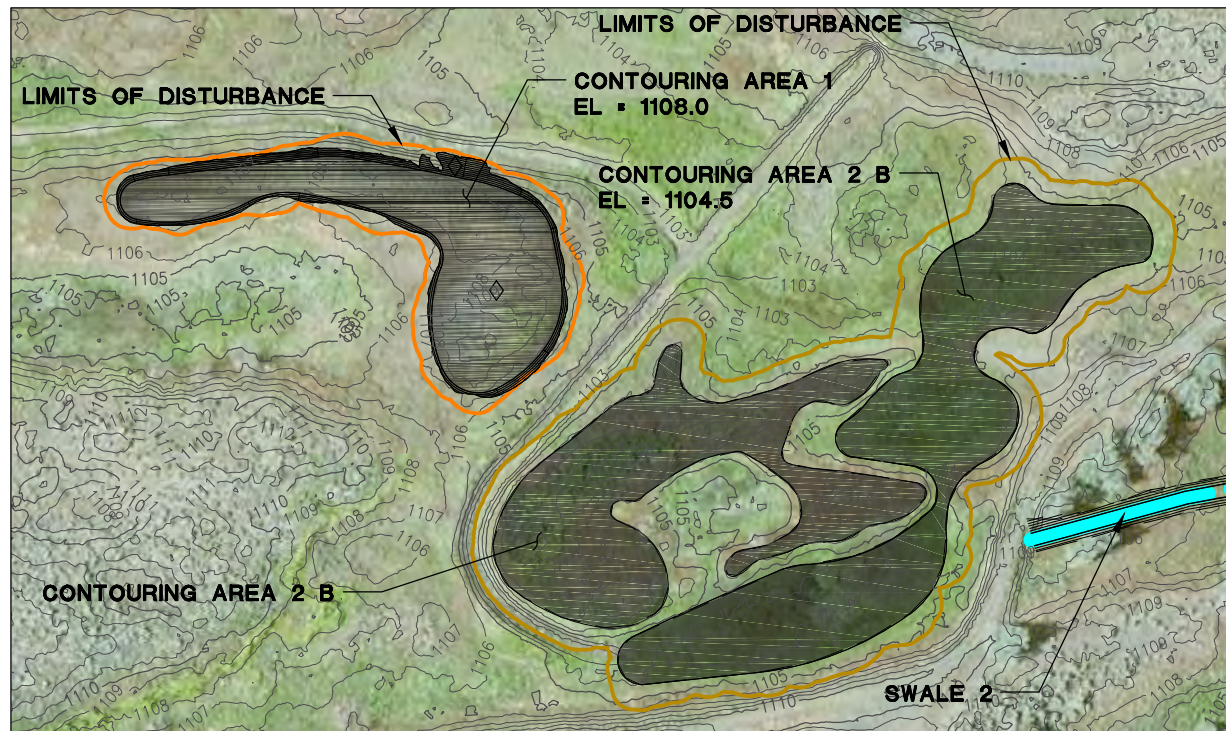
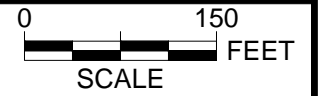

REFERENCE:

APPLICANT: WDFW

PROPOSED PROJECT: US-WA-320-2

LOCATION: TAX PARCEL 161217000

LAT/LONG: N 46.974748, W 119.451843

PAGE: 8 of 15

DATE: 1 NOV 16

Contouring Areas

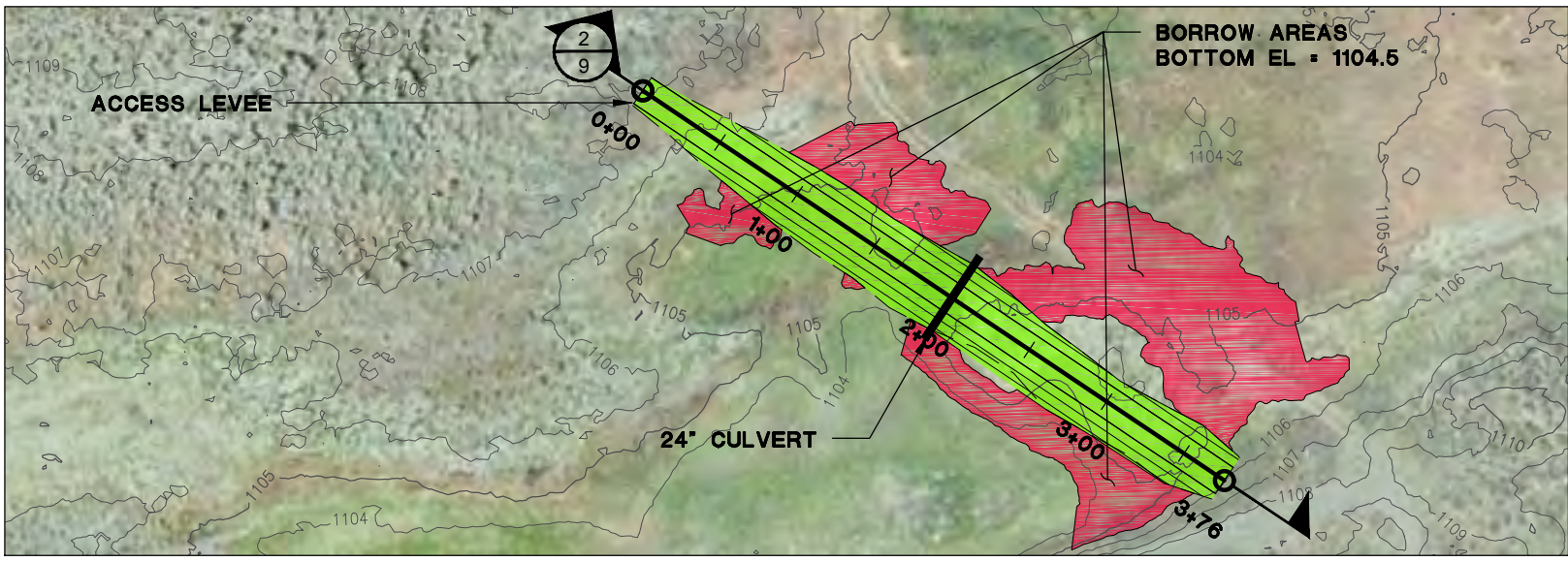
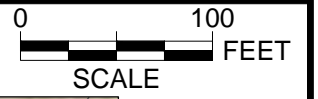

1 ACCESS LEVEL
9 PLAN VIEW

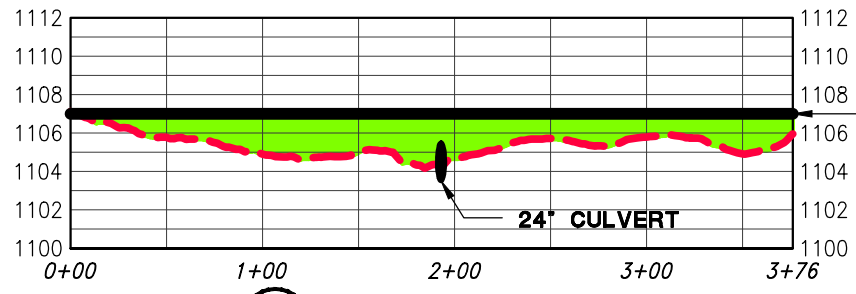

2 ACCESS LEVEL
9 SECTION

REFERENCE:

APPLICANT: WDFW

PROPOSED PROJECT: US-WA-320-2

LOCATION: Tax Parcel 161217000

LAT/LONG: N 46.974748, W 119.451843

PAGE: 9 of 15 **DATE:** 1 NOV 16

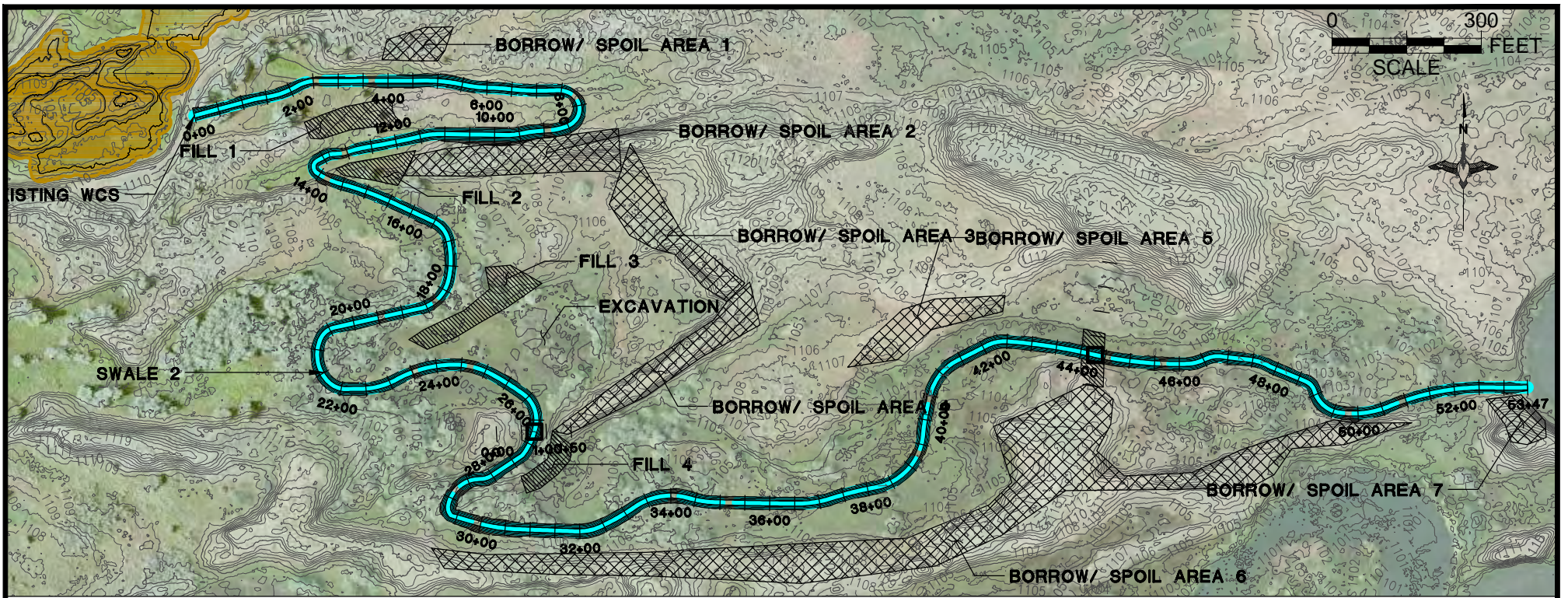

1 SWALE 2
10 PLAN VIEW

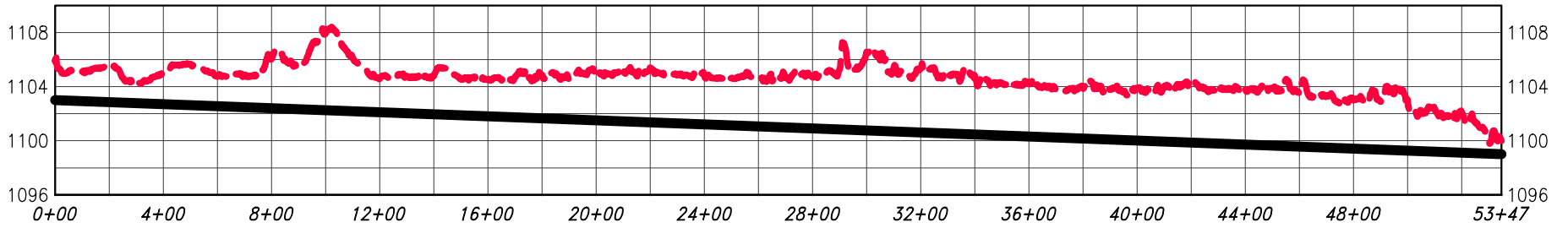

2 SWALE 2
10 PROFILE

REFERENCE:

APPLICANT: WDFW

PROPOSED PROJECT: US-WA-320-2

LOCATION: Tax Parcel 161217000

LAT/LONG: N 46.974748, W 119.451843

PAGE: 10 of 15 **DATE:** 1 NOV 16

Swale 2

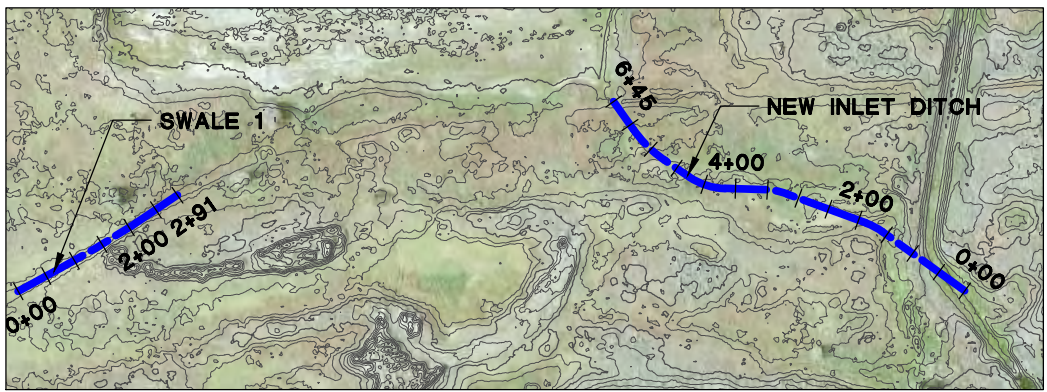

1 PLAN VIEW
11

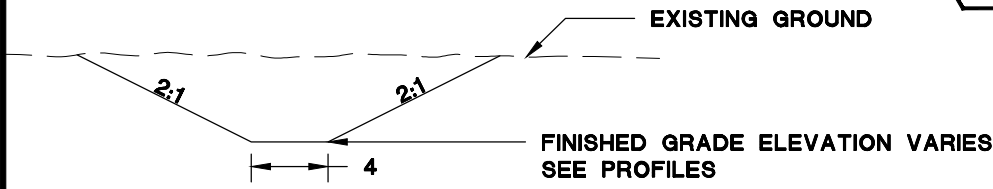

2 NEW INLET DITCH
11 TYPICAL

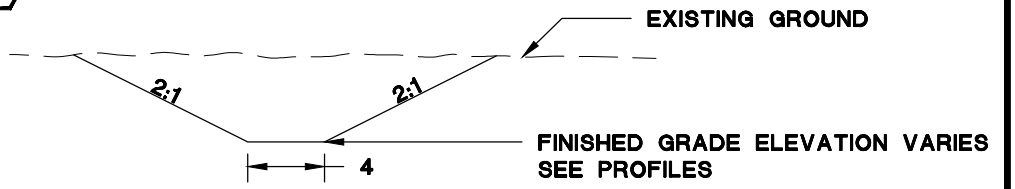

3 SWALE 1
11 TYPICAL

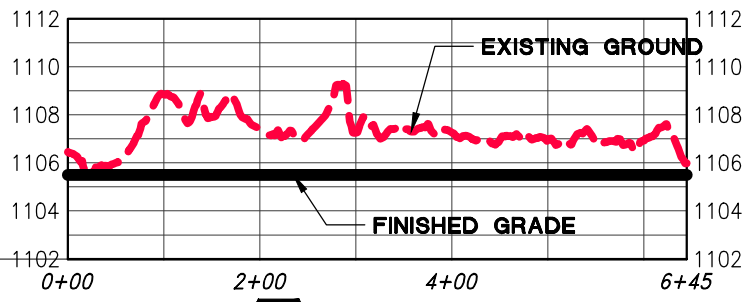

4 NEW INLET DITCH
11

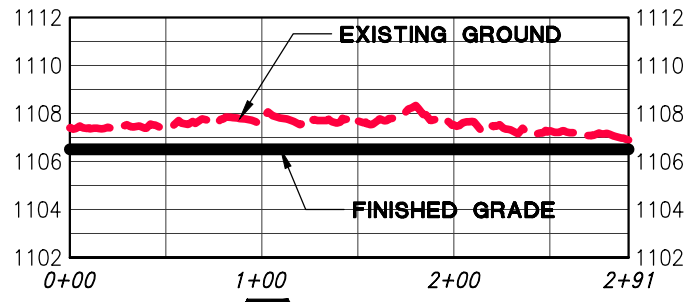

5 SWALE 1
11

REFERENCE:
APPLICANT: WDFW
PROPOSED PROJECT: US-WA-320-2
LOCATION: TAX PARCEL 161217000
LAT/LONG: N 46.974748, W 119.451843
PAGE: 11 of 15 **DATE:** 1 NOV 16

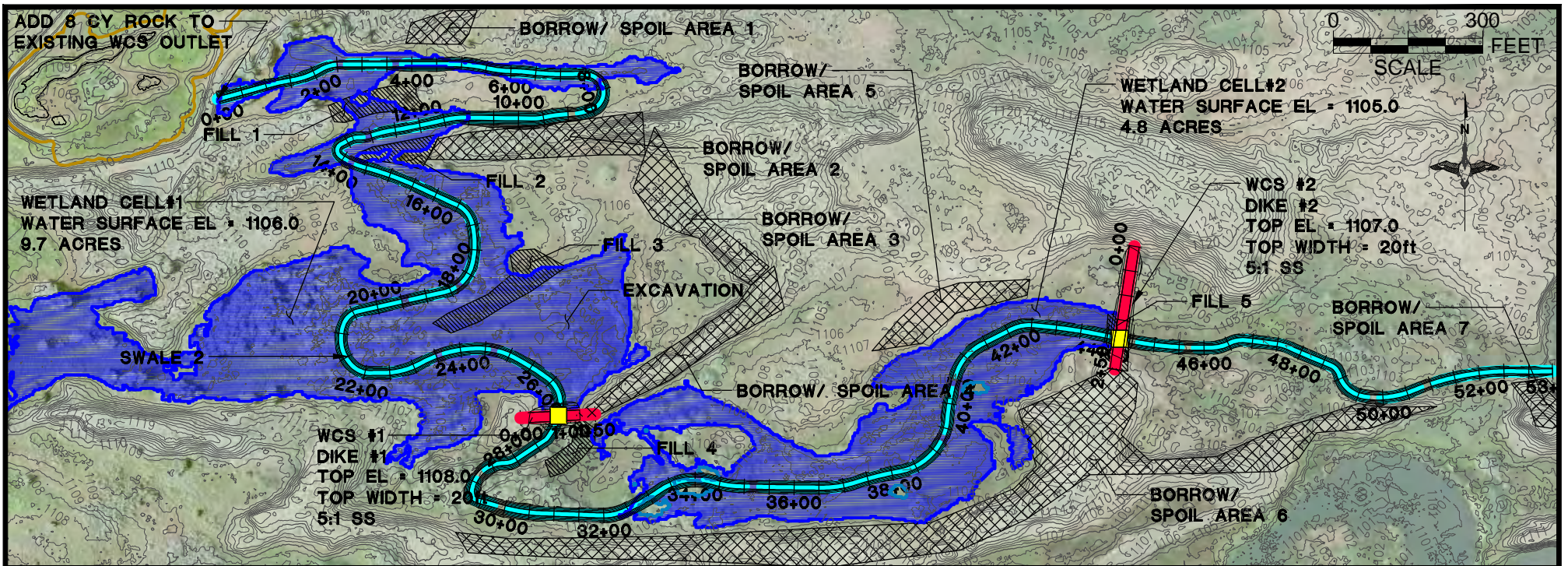

1 SWALE 2
12 PLAN VIEW

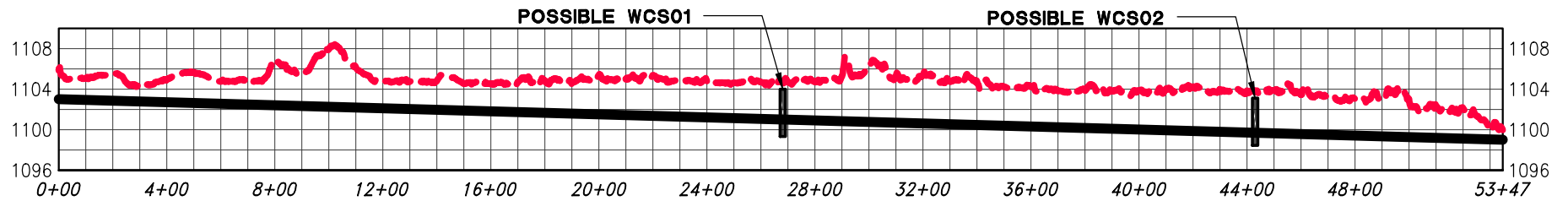

2 SWALE 2
12 PROFILE

REFERENCE:

APPLICANT: WDFW

PROPOSED PROJECT: US-WA-320-2

LOCATION: TAX PARCEL 161217000

LAT/LONG: N 46.974748, W 119.451843

PAGE: 12 of 15 **DATE:** 1 NOV 16

Swale 2 w/ Optional Dikes & Water Controls Structures

0 200
FEET

SCALE

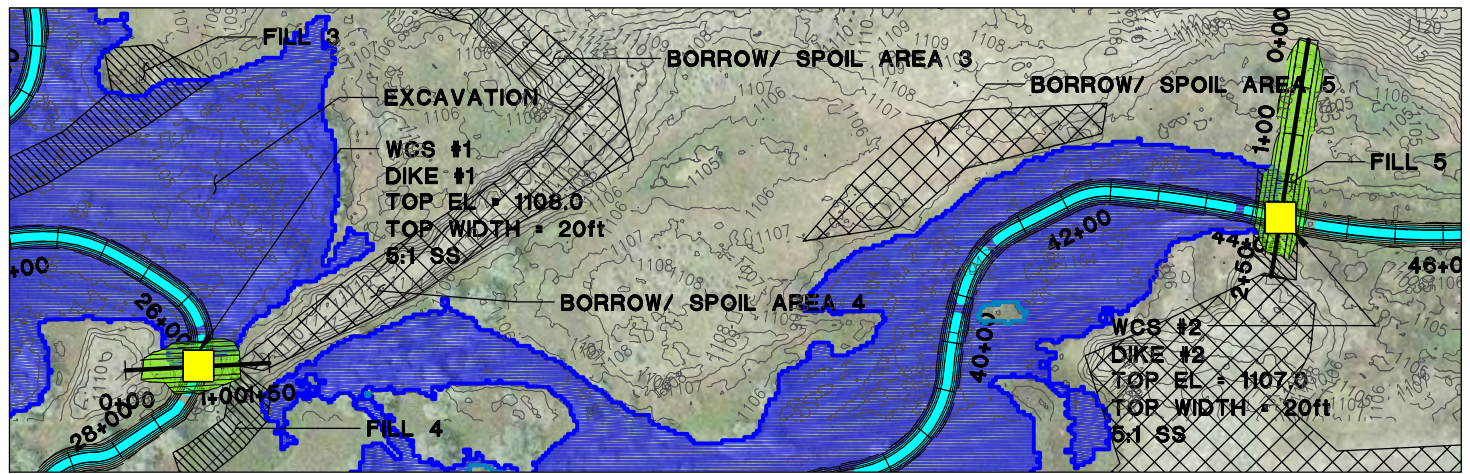

1 DIKE DETAIL
13 PLAN VIEW

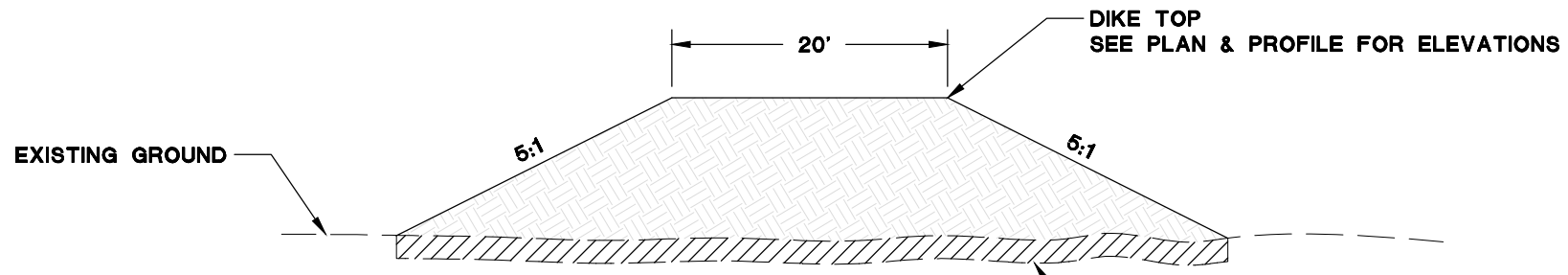

2 DIKE DETAIL
13 TYPICAL N.T.S. STRIP ORGANICS A MINIMUM OF 6" OR PER THE SPECIFICATIONS

REFERENCE:
APPLICANT: WDFW
PROPOSED PROJECT: US-WA-320-2
LOCATION: TAX PARCEL 161217000
LAT/LONG: N 46.974748, W 119.451843
PAGE: 13 of 15 **DATE:** 1 NOV 16

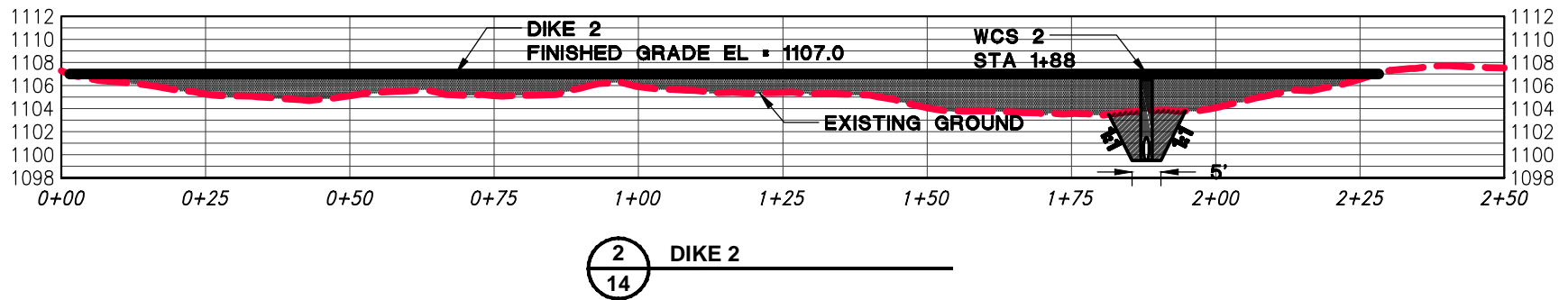
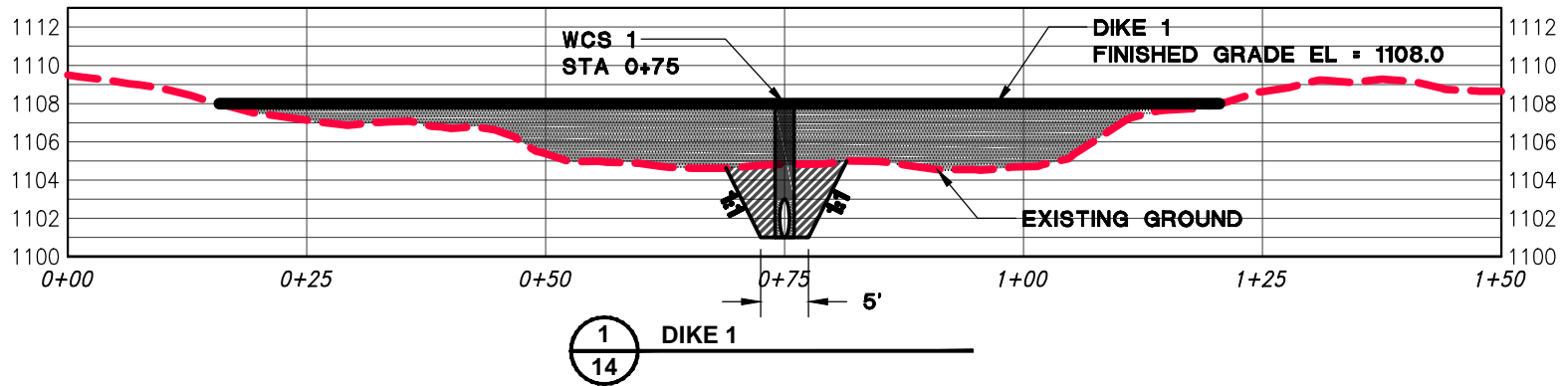

REFERENCE:

APPLICANT: WDFW

PROPOSED PROJECT: US-WA-320-2

LOCATION: TAX PARCEL 161217000

LAT/LONG: N 46.974748, W 119.451843

PAGE: 14 of 15 **DATE:** 1 NOV 16

Dike 1 & 2 Profile

AREA & VOLUMES

Item	Fill Area w/in wetland del., ACRES	Excavated Area w/in wetland delin., ACRES	Excavated Vol, CY	Fill Volume, CY	Comments
Island 1	0.58	0.14	380	380	
Island 2	0.02	0.04	180	180	
Island 3	0.00	0.00	0	0	
Island 4	0.00	0.00	0	0	
Island 5	0.00	0.00	0	0	
Access Dike	0.11	0.10	300	300	
Wetland Contour Area 1	0.00	0.00	0	0	
Wetland Contour Area 2	0.90	0.65	2904	2904	Assumed 2-ft fill
Inlet Ditch	0.16	0.16	341	341	
Swale #1 (bwtn wetland)	0.07	0.07	83	83	
Swale #2		3.09	12500		
Dike #1	0.10			250	
Dike #2	0.09			250	
Fill Area 1 along Swale #2	0.20			639	Assumed 2-ft fill
Fill Area 2 along Swale #2	0.14			437	Assumed 2-ft fill
Fill Area 3 along Swale #2	0.30			979	Assumed 2-ft fill
Fill Area 4 along Swale #2	0.12			381	Assumed 2-ft fill

REFERENCE:

APPLICANT: WDFW

PROPOSED PROJECT: US-WA-320-2

LOCATION: Tax Parcel, 161217000

LAT/LONG: N 46.974748, W 119.451843

PAGE: 15 of 15

DATE: 1 NOV 16

Quantity Summary